

Manual



Expert Power Sequencer 8112 Series



© 2024 GUDE Systems GmbH
Manual Ver. 1.2.1

Table of contents

1. Device Description	4
1.1 Security Advice	5
1.2 Content of Delivery	5
1.3 Description	5
1.4 Installation	6
1.4.1 Jack Plug Accessory	7
1.5 block diagram	7
1.6 Technical Specifications	8
2. Operating	10
2.1 Operating the device	11
2.2 Configuration	12
3. Support	14
3.1 Contact	15
3.2 Declaration of Conformity	15
Index	0

Device Description

1 Device Description

1.1 Security Advice

- The device must be installed only by qualified personnel according to the following installation and operating instructions.
- The manufacturer does not accept responsibility in case of improper use of the device and particularly any use of equipment that may cause personal injury or material damage.
- The device contains no user-maintenable parts. All maintenance has to be performed by factory trained service personnel.
- This device contains potentially hazardous voltages and should not be opened or disassembled.
- The device can be connected only to 230V AC (50 Hz or 60 Hz) power supply sockets.
- The power cords, plugs and sockets have to be in good condition. Always connect the device to properly grounded power sockets.
- The device is intended for indoor use only. Do NOT install them in an area where excessive moisture or heat is present.
- Because of safety and approval issues it is not allowed to modify the device without our permission.
- Please note the safety advises and manuals of connected devices, too.
- The device is NOT a toy. It has to be used or stored out of range of children.
- Care about packaging material. Plastics has to be stored out of range of children. Please recycle the packaging materials.
- In case of further questions, about installation, operation or usage of the device, which are not clear after reading the manual, please do not hesitate to ask our support team.
- Please, never leave connected equipment unattended, that can cause damage.
- Connect only electrical devices that do not have limited on-time. I.e. in case of failure, all connected appliances have to cope with a continuous on-time without causing damage.

1.2 Content of Delivery

The package includes:

- **Expert Power Sequencer 8112**
- Quick Start Guide

1.3 Description

The **Expert Power Sequencer 8112** is a PDU that switches load outputs with delay to avoid voltage peaks

- 6 power ports can be switched in a controlled switching sequence by switches on the unit or by external pushbuttons
- Sequential switching on and off of connected loads with a delay of 3s between adjacent outputs

Device Description

- The time interval can be set individually for each load output
- Current peaks during simultaneous switching operations and tripping of upstream fuses are prevented
- Jack connector allows connection of I/O contacts and switches and enables remote control of the switching routine
- Low power consumption
- Developed and produced in Germany

Additionally for **EPS 8112-2 / 8112-4 / 8112-6**:

- Integrated overvoltage protection type 3 (according to EN61643-1) prevents damage to the device and connected loads
- Integrated mains filter prevents interference currents and thus eliminates loss of signal quality for connected devices such as loudspeakers, amplifiers and beamers

1.4 Installation

Connectors



1. Switch for the on/off sequence
2. Status LED
3. jack socket for external switch
4. LED for overvoltage protection (**EPS 8112-2 / 8112-4 / 8112-6**, red - protection inactive)



6 x Load outputs to consumer (**EPS 8112-1 / 8112-2 / 8112-6**, IEC C13, max. 10 A)

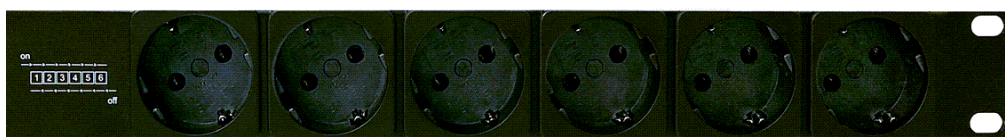

Device Description

6 x Load outputs to consumer (**EPS 8112-3 / 8112-4**, CEE 7/3 type F, max. 16 A)

Start-up the device

- Connect the load input to the mains supply.
- Connect the load outputs with the consumer.

1.4.1 Jack Plug Accessory

The **Expert Power Sequencer 8112** can optionally be remote controlled by an external switch with cable. The **Jack Plug Adapter 7960** (3.5 mm, 3-pole) can be purchased as an accessory.



The jack plug (1) is plugged into the front panel of the EPS 8112. Between (2) and (4) an external potential-free switch is connected. An possible additionally LED (3) in the switch can be controlled. This LED is internally connected to 5V with a 560R resistor.

1.5 block diagram

This block diagram illustrates the structure of the EPS 8112-4. Other models do not have overvoltage protection and line filters, or have a different type of load outputs.

Device Description

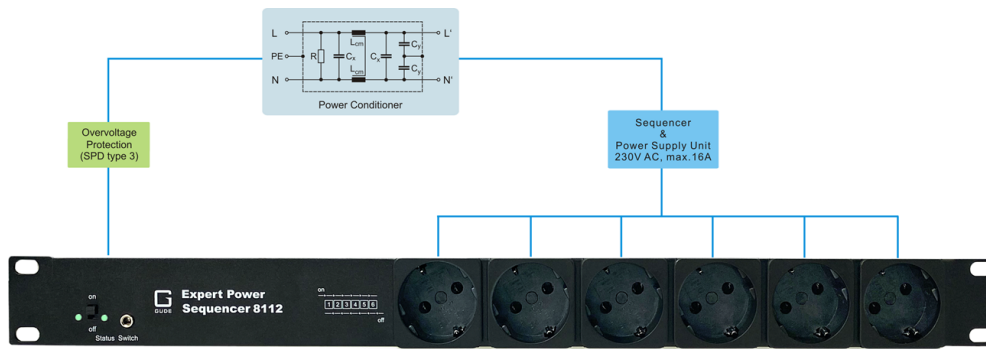

Layout of Expert Power Sequencer 8112-4

1.6 Technical Specifications

Interfaces	EPS 8112-1 / 8112-2 1 x fixed Mains supply (CEE 7/7 safety plug type E+F, max. 16 A, 230 V, cable length 2m) 6 x Load outputs (IEC C13, max. 10 A) 1 x jack socket (3.5 mm, 3-pole) for external switch
	EPS 8112-3 / 8112-4 1 x fixed Mains supply (CEE 7/7 safety plug type E+F, max. 16 A, 230 V, cable length 2m) 6 x Load outputs (CEE 7/3 safety plug, max. 16 A) 1 x jack socket (3.5 mm, 3-pole) for external switch
	EPS 8112-6 1 x fixed Mains supply (IEC C20, max. 16 A, 230V, cable length 2m) 6 x Load outputs (IEC C13, max. 10 A) 1 x jack socket (3.5 mm, 3-pole) for external switch
Environment	<ul style="list-style-type: none"> Operating temperature: 0°C - 50 °C Storage temperature: -20°C - 70 °C Humidity: 0% - 95% (non-condensing)
Case	powder coated, galvanized steel sheet
Measurements / Weight	EPS 8112-1 / 8112-3 19" (inches), 1 Rack Unit, (Depth 62 mm) approx. 1.535 kg
	EPS 8112-2 / 8112-4 / 8112-6 19" (inches), 1 Rack Unit, (Depth 112 mm) approx. 2.055 kg

SPD according to EN 61643-1 type 3 / class III (EPS 8112-2 / 8112-4 / 8112-6)

rated voltage U_n AC	230V 50Hz / 60Hz
max. cont. operating voltage U_c AC	265V 50Hz / 60Hz
nominal discharge current I_n (8/20) μ s	3 kA
total discharge current I_{total} (8/20) μ s	5 kA

Device Description

combination wave U_{OC}	6 kV
nominal load current	16 A
voltage protection level U_p (L-N)	< 1,3 kV
voltage prot. level U_p (L-PE, N-PE)	< 1,5 kV
response time t_A (L-N)	< 25 ns
response time t_A (L / N-PE)	< 100 ns
max. backup fuse	B 16 A
number of ports	1
signaling	LED: green ok, red flashing protection inactive

EMC/EMI Mains Filter (EPS 8112-2 / 8112-4 / 8112-6)

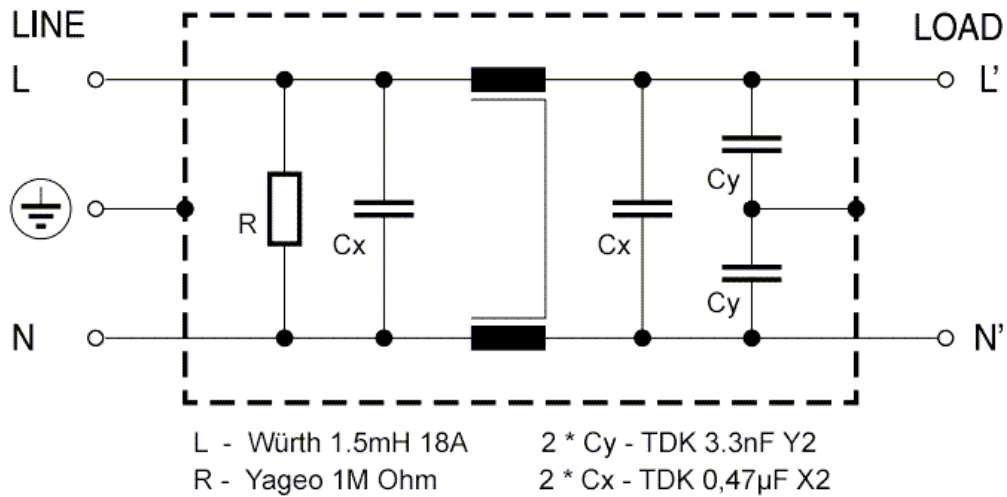

Operating

2 Operating

2.1 Operating the device



In the initial position the front switch (1) is in position "off" and all load outputs are switched off. The status LED (2) lights up red. If the switch is set to "on", the 6 load outputs are switched on one after the other at intervals of approx. 3 seconds (configurable). The status LED flashes green. The status LED flashes once for the first load output, twice for the second load output, etc. until the status LED flashes six times for the last load output. At the end the status LED lights up permanently green.

If you now want to switch off the loads with a delay, set the switch to "off" and the output switching-off process is carried out every 3 seconds in reverse order to the switch-on process. The status LED flashes red six times and the sixth (last) load output is switched off. Then the fifth load output follows until at the end of the sequence the first load output is also switched off. The status LED is now permanently red. The sequence during the switch-off process is configurable.

 A switch-on or switch-off sequence cannot be interrupted. The position of the switch (1) is only taken into account again at the end of a sequence.

Operation with optional external switch

If a jack plug with switch is plugged into the jack socket (3), the front switch (1) loses its function and the device can only be controlled via the external switch. As with the front switch, closing the switch starts the switch-on sequence when all load outputs are off. Opening the external switch initiates the switch-off sequence when all load outputs are on. If an LED is connected to the external switch, the LED will be permanently lit at the end of the power-up sequence. If all load outputs are switched off, the switch LED flashes slowly.

Overvoltage Protection

The device has an overvoltage protection (SPD) (EPS 8112-2 / 8112-4 / 8112-6). This is based on input-side varistors with a thermal fuse between phase (L) and neutral (N) and a gas discharge tube to ground (PE) to protect the internal electronics and the load outputs with failure detection (thermal fuse permanently tripped). The status of the protection is indicated by an LED (4) on the front panel. If the LED is green, it means that the protection is ready for operation, if the LED flashes red, it means that the overvoltage protection module is out of order. Each surge protection module is designed to discharge a virtually unlimited number of surge pulses in normal installation environments. In an environment with many high-energy overvoltage pulses, aging of the overvoltage protection element can cause a permanent failure of the function.



The surge protection function can only be restored by the manufacturer of the device. Normally, the device will continue to operate even after the failure of the protective function.

2.2 Configuration

The EPS 8112 is configured in the delivery state in such a way that the ports are switched on one after the other every 3 seconds. The switch-off process takes place at the same interval, but in reverse order. The preset values are chosen in such a way that normally no adjustments are required. If one uses the EPS 8112 e.g. in a media control with amplifier, one can arrange the devices in such a way that the amplifier is switched on last, but switched off first. However, one has the possibility to change the switch on waiting times and the order of switching off.

Initiate programming mode

- a) You enter the programming mode when you switch on and off 2 times. Each switching operation must be < 2 sec. After that the LED flashes alternately red-green.
- b) Please make sure that the ports of the EPS 8112 are switched off so that the programming mode can be started.
- c) The programming mode is exited directly when the external connector is plugged in.
- d) During programming mode, the optional LED for overvoltage protection is not active.

Resetting all values (3 sec switch-on delay and descending switch-off sequence.)

- a) Start programming mode.
- b) Switch to "On" within 3 sec.
- c) After 5 sec. the red-green change flashes faster.
- d) Wait another 5 sec, then the LED flashes 3x red.
- e) Turn off, and the EPS 8112 is in the switched off state (outside programming mode).

Reversing the direction of the switch-off process

- a) Start programming mode.
- b) Switch to "On" within 3 sec.
- c) After 5 sec. the red-green change flashes faster.
- d) Switch off within 5 sec, then the LED flashes green 3 times.
- e) The EPS 8112 is in the switched off state (outside programming mode).

Set all ports to the same waiting time

- a) Start programming mode.
- b) Wait 3 sec, the LED flashes 3x orange.
- c) If you stay off for 5 sec, you are out of programming mode.
- d) Switch to "On" to set the time, then the LED flashes red every second.
- e) After the desired time switch to "Off" (for N seconds - N x flashing).
- f) The EPS 8112 is in the switched off status (outside programming mode).

 The minimum waiting time when switching on is 2 sec. and the maximum time is 60 sec, even if a different time has been configured. The waiting time when switching off is always fixed at 3 sec.

Example: All ports set to 10 sec

- 2x switch on and off (programming mode)
- wait 3 sec. - LED flashes 3x orange
- switch on - wait 10 sec. - switch off

Set one or more ports to a waiting time

- a) Start programming mode
- b) To select the Xth port, switch on and off X times.

 If you switch several times and wait more than 5 sec. in position "On", the programming mode will be left.

- c) Wait 3 sec, the LED flashes green X times.
- d) If one does nothing for 5 sec, then one is out of the programming mode.
- e) To set the time, switch to "On", then the LED flashes red every second.
- f) Switch off after the desired time (for N seconds - N x flashing).
- g) Now the X+1th port is selected, switching on continues at b), waiting 3 sec. continues at c).

 The minimum waiting time when switching on is 2 sec. and the maximum time is 60 sec, even if a different time has been configured. The waiting time when switching off is always fixed at 3 sec.

Example: Set the time of port 2 to 7 sec, port 3 to 8 sec. and port 5 to 10 sec.

- 2x on and off (programming mode)
- switch 2x on-off - selects port 2
- wait 3 sec. - LED flashes 2x green
- switch on - wait 7 sec. - switch off
- wait 3 sec. - LED flashes 3x green
- switch on - wait 8 sec. - switch off
- 5x switch on - off - selects port 5
- wait 3 sec. - LED flashes 5x green
- switch on - wait 10 sec. - switch off
- Wait 5 sec, EPS 8112 exits programming mode

Support

3 Support

If you have further questions about installation or operation of the unit, please contact our support team. Furthermore, we present in our support wiki at www.gude.info/wiki FAQs and configuration examples.

3.1 Contact

GUDE Systems GmbH
Von-der-Wetteren-Straße 23
51149 Cologne
Germany

Phone: +49-221-985 925 0
Fax: +49-221-985 925 97
E-Mail: info@gude-systems.com
Internet: www.gude-systems.com

Managing Director: Dr.-Ing. Michael Gude, Andreas Boettcher, Philipp Gude

District Court: Köln, HRB-Nr. 17 7 84
WEEE-number: DE 58173350
Value added tax identification number (VAT): DE 122778228

3.2 Declaration of Conformity

This product from the **Expert Power Sequencer 8112** series is in conformity with the European directives for CE marking applicable to this product. The complete CE declaration of conformity for this product can be found on the website www.gude-systems.com in the download section of the product.



Expert Power Sequencer 8112
© 2024 GUDE Systems GmbH
10/17/2024